

## Product description

The GEFA valves series AT200F are provided for use in the area of solid substances. The valve is usable as a product tight valve.

Valves of the AT 200 series can be installed between flanges or as inlet / outlet valves.

It has to be taken into account that a valve which is manufactured for a certain flange norm usually cannot be used for other flanges. It has to be checked with the manufacturer if pipe flanges can be used which do not correspond to the ordering specification.

## Maximum operating excess pressure (pmax)

Independent of the PN level of the valves, the following maximum operating excess pressures (pmax) must be heeded:

DN	pmax [bar]
200 - 300	10
350 / 400	6
500 - 600	4
700 - 900	3
1000	2,5

**Danger:** The maximum operating excess pressure refers to the working pressure of the valve. The maximum or reduced explosion pressure usually exceeds the working pressure several times over. For this reason, the limits of application according to 94/9/EG must always be observed. Depending on the medium and operating conditions it can be necessary to reduce the working pressure considerably in order not to exceed the limits of application according to 94/9/EG in the event of an explosion.

## Limits of application acc. 94/9/EC

The valves have been designed for use in potentially explosive areas.

The valves have been classified in Device Group II. The following device categories are valid:

 II 1D/3DG c

Category 1D inside the valve / Category 3D or 3G outside the valve.

or

 II 1D/2DG c

Category 1D inside the valve / Category 2D or 2G outside the valve.

DN 200 – DN 600

The resistance to explosive pressure according to VDI 2263, Page 3 is 18 bar for the valve housing.

Valves in closed position are igniting disruptive resistant up to 10,1 bar against organic dust explosions of dust explosion class St1.

DN 700

The resistance to explosive pressure according to VDI 2263, Page 3 is 10,1 bar for the valve housing.

Valves in closed position are igniting disruptive resistant up to 10,1 bar against organic dust explosions of dust explosion class St1.

DN 800 – DN 1000

The resistance to explosive pressure according to VDI 2263, Page 3 is 6 bar for the valve housing.

Valves in closed position are igniting disruptive resistant up to 6 bar against organic dust explosions of dust explosion class St1.

## Maximum surface temperature

The surface temperature of the valve is determined by the temperature of the operating medium.

Any increase in temperature due to frictional warmth is negligible, since the relative speed of the moving parts is extremely low.

The connection between the temperature of the conducted medium, the temperature class and the device category can be seen in the following table.

Device category	Temperature of the operating medium [°C]	Temperature class
II 3G or II 2G	58	T6
II 3G or II 2G	70	T5
II 3G or II 2G	98	T4
II 3G or II 2G	150	T3

The temperature of the operating medium must not exceed 150 °C on account of the seals used.

The ignition temperature of whirled up dust must be at least 1.5 times the temperature of the conducted medium.

The glow temperature of dusts deposited on the valve must be at least 75 °C greater than the temperature of the operating medium, whereby the thickness of the dust layer must not exceed 5 mm.

## Marking acc. 94/9/EC

The valves are marked with the following details:

- GEFA Dortmund
- AT 200F
- Nominal width
- PN level
- Maximum operating excess pressure (p<sub>max</sub>)
- Permissible environmental temperature: -20 °C ≤ T<sub>a</sub> ≤ +60 °C
- Serial number
- Month and year of manufacture
- Certificate number
- **CE 0158**
- Explosion protection mark

 II 1D/3DG c

Category 1D inside the valve / Category 3D or 3G outside the valve.

or

 II 1D/2DG c

Category 1D inside the valve / Category 2D or 2G outside the valve.

## Operator's duty of care

GEFA valves are designed and manufactured after careful selection of the standards and technical specifications to be met. They are state of the art and allow the maximum level of safety during operation.

Design modifications may only be carried out with the written permission of the manufacturer.

Safety during operation can only be guaranteed if all of the required measures are taken. It is part of the operator's duty of care to plan and check these measures.

The operator must particularly ensure that:

- The valve is only used for its intended purpose.
- The material of the valve is selected acc. to the working conditions.
- The valve is only operated in a perfect, serviceable condition.
- The operating instructions are constantly available at the place where the valve is to be used.
- The valve is only operated, maintained and repaired by suitably qualified personnel.

## Transportation

To prevent damage and serious injury during transportation of the valve:

- Only suitable and perfect load suspension devices and lifting tackle should be used.
- Take the weight of the valve into account when selecting the load suspension device and lifting tackle.
- Transportation routes are to be blocked and clearly marked so that unauthorized persons cannot enter the danger area.
- Transportation work should only be carried out by qualified and authorized persons wearing suitable protection clothes.

To prevent damage of the valve:

- The transportation of the valves to their final destination (building site) must be done in a solid box adapted to the size of the valve taking into account the type of transport as well as any applicable regulations.
- The valves must be suitably protected against external damage and atmospheric effects.
- Depending on the duration of transportation and storage and also with regard to the climatic conditions, preservation must be made by means of gas treatment or by shrink-wrapping and sealing the valve in polyethylene film that also has an adequate amount of a desiccant such as silica gel placed inside.

## Storage

- The valves should be stored indoors in a dry place until final installation. All working parts must be suitably covered to protect them against humidity, dust or other soiling.
- Temperatures for storing: - 15°C to + 30°C
- In humid rooms drying material respectively heating is necessary to avoid condensation of water.
- During a longer period of storage or in the case of unfavourable storage conditions that might affect subsequent functioning, all metallic bright surfaces such as the spindle, piston rod, and sealing surfaces must be effectively protected against corrosion by means of a suitable and durable corrosion preventative.
- The corrosion preventative applied at the factory must be checked for any damage in transit and suitably repaired if needed.
- Valves have to be protected against force (shock, blow, vibration etc.).
- During storage or transport the ball valve must be either in open or closed position (no intermediate position!).
- For parts mounted on the valves, such as electrical actuators, limit switches, valves, etc., the corresponding storage instructions of the relevant manufacturers shall have priority.

## Valve housing coating

**Danger:** The coating of the valve housing has been designed in such a way as to prevent danger due to static charge. For this reason, no changes may be made to the coating of the valve housing. If the coating of the valve is changed, ignitable discharge could occur as a result of static charge.

## Actuators

Note: actuators and accessory parts mounted or provided by the customer (e.g. solenoid valves) must correspond to the outer device category of the valve (3D, 3G, 2D or 2G).

## Installation

- Observe the maintenance and repair instructions for the individual components.
- **Danger:** moving parts may cause injury.
- **Danger:** Operation of electrically, pneumatically, or hydraulically-operated valves that have not yet been installed is not permitted.
- To prevent the danger of stumbling: Place all connections (cable, hose pipes and tubing) in such a way that they will not cause any stumbling (cable ducts, bridges etc).
- Before the final installation of the valves, any corrosion preventative that has been applied as per section 2.2 above must be thoroughly removed. All parts, and in particular the valve plate, spindle and piston rod, must be free of dust and dirt and, if necessary, well lubricated with a suitable lubricant before being used for the first time.
- Damage to the protected surfaces arising during installation or transport must be repaired by an expert. Damage of this type is not covered by the warranty.
- Protection of the Valve  
If there is construction work still going on near or above the valves, they must be covered to protect them against this construction work.  
When painting the installation, the spindle, electrical components and the plate projecting from the housing when the valve is open must not be painted. Any solvents used to remove unwanted paint must not come into contact with the seals under any circumstances. This applies especially to the area where the valve plate projects from the housing. If the installation is to be first cleaned by sand-blasting, the valves must be covered with special care.  
Debris from sand-blasting, and especially sand-blasting grit, which gets into those parts of the installation that will be in contact with the valve during subsequent operation of the installation, must be removed carefully. Sand-blasting grit can destroy the valve plates and seals within a very short time.
- The possible locations for installing the valve must be selected such that surfaces A and B are freely accessible for both sides to allow the seals to be readjusted if necessary.  
Ensure that there is the necessary amount of space (200mm) available for the packing tool C.
- Valves should normally be installed upright in horizontal pipelines, i.e., actuator on top, and horizontally in vertical pipelines.  
The position of installation of the respective valve must be chosen so that operation will be affected as little as possible by the medium.  
In the case of technically difficult installation conditions or in the case of custom-made valves, please contact the manufacturer if there is any doubt regarding the exact position of installation.
- The direction of flow must be according to the direction of the arrow in custom-made valves.
- The pipes must not have any tension.
- Prior to the mounting of the valve flush the pipelines to remove all traces of soiling, welding residues etc.
- Check whether the flange clearance is in accordance with the face-to-face dimension of the valve.
- Before mounting the valve, the flanges are to be sufficiently spread using a suitable tool.
- **Danger:** From size 600 mm flange gaskets with supporting ring (e.g. spiral-wound gasket with outside ring) must be used, because the permitted explosion pressure is higher than the nominal pressure of the valve / flange connection  
These gaskets are recommended for valves up to size 500 mm.
- Insert the valve and the gaskets between the flanges.
- Insert flange screws and nuts.
- Remove the spreader and hand-tighten the screws.
- Check whether the valve, the gaskets and the counter-flanges are in true alignment.
- Before the flange screws at the area of the thread blind holes of the valve are tightened, the through screws lying besides have to be tightend.
- Tighten the flange screws crosswise using the stipulated torque.  
The tightening moment depends on the seat material chosen.  
If there are no details available, the following reference values can be used:

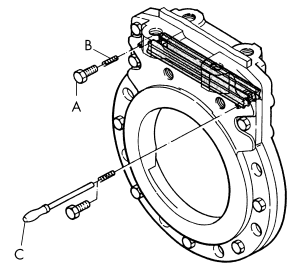

M16 = 125 Nm      M20 = 240 Nm      M24 = 415 Nm

M27 = 610 Nm      M30 = 830 Nm      M33 = 1100 Nm

## Putting into operation

- Flush the pipe and valve and clean them of any impurities (e.g. welding residue).
- Before finally putting the valves into service, all the important elements (plate, spindle, piston rod, etc.) must be cleaned thoroughly. Any damage to the plate, especially to the seal as a result of sand-blasting debris or welding beads, external rust, etc., is not covered by the warranty.  
Cleaning agents that include solvents especially those based on aromatic hydrocarbons (thinners, petroleum spirit and the like) must not be allowed to get into contact with the seal.
- Actuators must be mounted in alignment to the valve stem. Wrong mounting will lead to a higher wear of the stem packing or cause leakage.
- The mounted actuator must not cause a thrust load on the valve shaft. If necessary the actuator must be fastened / supported. NOTE: In case of moving pipelines the fastening of the actuator must not be rigid.
- Pneumatic or hydraulic actuators must be operated with the agreed design pressure. The actuator's maximum permissible operating pressure must be observed.
- Check that all the required connections (e.g. electrical connections, compressed air hose connections) have been plugged in and the connectors are secure.
- When shutting off powdery or granular media, ensure that any wetness or humidity caused by the installation work and which might cause a subsequent caking of the medium must be thoroughly removed before the installation is started up when using the medium. Malfunctions of the valve caused by agglutination or caking of powdery media are not covered by the warranty.
- **Danger by static charging:**  
To protect against static charging the valve has to be grounded.  
The gate is connected conductively with the body by an antistatic device.  
Since the housings are plastic coated, a conductive connection of the pipe flange via a respective seal is **not** guaranteed.  
For a conductive connection between valve and pipe the thread blind holes in the upper area of the body can be used. Those thread blind holes are not coated.  
To ensure a durable conductive connection toothed lock washers have to be placed under at least two screw heads of the screws for the thread blind holes.  
It has to be taken into account that the pipe flange is free of isolating coatings in the area of these tooth lock washers.  
If the valve shall be grounded directly, then the grounding latches can be connected to the gate on the antistatic device.
- Check the function of the valve. If the function valve might not work properly, the valve must be replaced.

## Pneumatically-operated valves

- Before initial operation, all the air lines provided by the customer as well as the pneumatic control valves must be thoroughly blown and also cleaned if necessary.
- We recommend the use of lightly oiled compressed air to actuate the cylinder. In operation, 1-2 drops per 1000 litres of air will be sufficient.
- Unless explicitly stated otherwise when ordering, pneumatic control valves installed by us are supplied without accessories such as chokes or silencers. The stipulations at the customer's site must be followed.
- Pneumatically-operated valves should not be closed suddenly, as otherwise there is a risk of pressure shock.

## Hydraulically-operated valves

- Before initial operation, all the control lines provided by the customer must be thoroughly cleaned.
- Hydraulically-operated valves should not be closed suddenly, as otherwise there is a risk of pressure shocks. Choker valves set at the factory must not be altered.

## Electrically-operated valves

- Closing may be done exclusively according to our instructions, as follows:
  - only switch off in the closing direction by using a torque switch.
  - only switch off in the opening direction by using the path switch, the torque switch that is there serves as overload protection and must also be closed.
- In the case of freely programmable controllers, the path switch and torque switch must be connected immediately before the contactor coils. For functional reasons, only self-locking actuators may be used.
- Signal transfer at the path switch and torque switch to switch off the electrical actuator must be done in real time. Signal chaining via multiple contactors or positioning units causes the drive units to run on and can lead to the destruction of certain components.
- To avoid any risk of damage to the valve before it is operated electrically for the first time, move the plate by hand to the middle position and only then operate the valve by means of the actuator.
- Check the phase sequence when connecting the power supply. The path switch and torque switch cannot operate if the phase sequence is wrong.
- The electrical actuator may not be operated unless the torque and limit switch function correctly. The torque set at the factory must not be changed. If it is necessary to do this in exceptional cases, only do so after consulting the manufacturer.
- The heating and thermo-switches must be connected without fail to avoid a buildup of condensation and overheating of the motor. Follow the special operating instructions of the relevant actuator manufacturer.

## Normal operation

- The valve should only be operated by persons who are trained and authorized to do so, and who know the operating instructions and work accordingly.
- **Danger:** It must be guaranteed that the feed flow is free from any foreign bodies that could act as an ignition source.
- **Danger:** Removal of the protective cover, except for installation, maintenance and / or repair work, is not permitted.
- **Danger:** The user has the responsibility for taking care that all risks of accident are avoided by taking suitable precautions in the danger zone for valves used as inlet valves. (The legal stipulations are to be followed here.) Before entering the danger area it must be guaranteed that the valve is completely closed (and thus ignition-proof).

For this reason the valves are generally to be designed with an end position indicator.

Used end position indicators (e.g. limit switch or proximity switch) must have high safety standard against malfunctions (e.g. switches featuring with positive opening contacts).

Visual control of the gate position must be carried out even if end position is indicated by limit switches.

For this purpose the factory-made marking on the gate can be used. The marking is located on the right side at the inlet side of the valve. The gate has reached the position "CLOSED" if the line below the arrow is in alignment with the upper edge of the valve body.

Valves with covered gates have to be equipped with a visual position indicator.

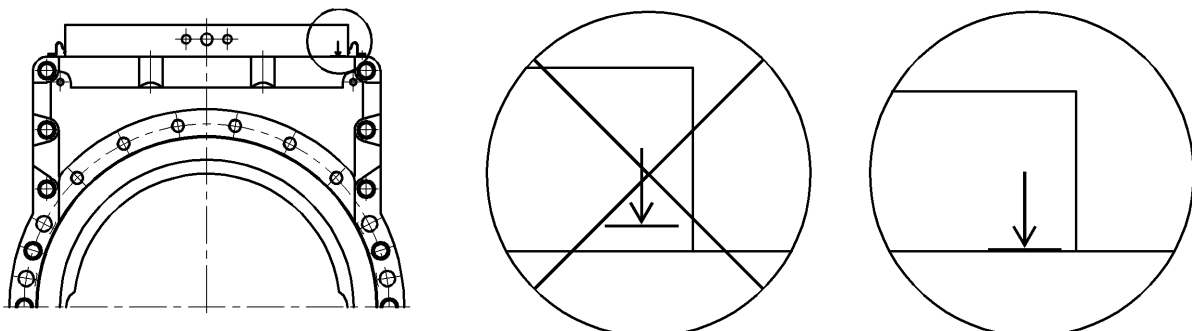

- If the valve is seldom operated, and especially in the case of automatic valves, a test run should be made at least every 3 months to ensure permanent readiness for use and to avoid deposits from becoming baked on.

## Maintenance and repair

- Maintenance should only be carried out by qualified and authorized persons.
- Observe the maintenance and repair instructions for the individual components.
- Resistance to pressure impact and ignition:  
Resistance to pressure impact and ignition is achieved by the use of a sealing system as well as through component design.  
**Danger:** In the event of heavily worn or damaged seals the resistance to explosive pressure and ignition are not guaranteed.  
In order to guarantee the resistance to impact pressure and ignition, it is recommended to check the valve once a year for leaks. Depending on conditions of operation and use a shorter inspection interval can be necessary. If leaks are found, these must be eliminated as indicated below.
- **Danger:** Removal of the protective cover, except for installation, maintenance and / or repair work, is not permitted. After dismantling the protective cover to carry out installation, maintenance and / or repair work, attention should be paid to the movable parts of the valve.
- **Danger:** Before starting maintenance or repair, ensure that any parts of the valve which may be touched have cooled to room temperature.
- **Danger:** Check whether the pipeline has been rendered depressurized and is empty.
- **Danger:** Check whether pneumatic or hydraulic actuators have been rendered depressurized.
- **Danger:** Before starting maintenance or repair work, the pneumatic or hydraulic cylinders and the piping system must be checked for residual energy (e.g. pressure buffer).
- **Danger:** Automatic or remotely-operated valves must be disconnected from the automatic operation system or remote control system for the duration of the maintenance or repair work.
- **Danger:** Pneumatic cylinders equipped with an opening or closing spring may only be disassembled at the factory of the manufacturer. It is important to observe the maintenance and repair instructions.
- **Danger:** Maintenance work for parts which are in contact with dangerous materials or liquids should only be carried out by persons wearing suitable protection clothes.
- Only original spare parts should be used.
- Readjusting the seal:  
During prolonged storage and in the event of larger temperature fluctuations, the sealing material of the seal of the narrow face may shrink or else release air trapped in the seal and thus can cause minor leakages on the narrow face of the plate. If any leakage is found in the transverse seal in initial operation during the pressure test or after readjusting the seal (as per the instructions for installation of the block profile transverse seal) or after a prolonged period of disuse, and this still persists even after operating the valve several times, then the seal can easily be re-tensioned while the valve is still installed. The valve should not, however, be under full operating pressure when this work is done.
- Minor leaks:  
Minor leaks can be eliminated by tightening the packing hole screws (A). If this does produce any significant improvement, remove the packing hole screws (A) and apply the packing material (B) by means of the packing tool (C) until the valve is tight. In the case of valves sealed with a transverse seal, take care that the packing tool is pushed into the hole provided in the seal and the packing material is compressed between the seals. The packing hole screws (A) should be tightened up again by about 3 turns.
- Major leaks:  
Major leaks are an indication of worn or damaged seals.  
If the leak cannot be eliminated by the packing method described above, the valve sealing system must be replaced.  
Replacement of the seals is to take place according to the operating instructions "Maintenance / Seal Replacement Series AT". It is recommended to have the manufacturer carry out the seal replacement.  
**Danger:** In the event of heavily worn or damaged seals the resistance to explosive pressure and ignition are not guaranteed.

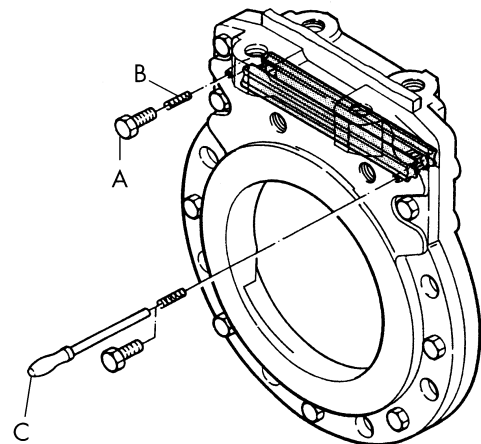

- Lubrication of valves with hand-wheel operation:  
The spindle must always be kept well greased and free of dirt. The greasing points on the hand wheel bearing must be regreased regularly depending on the conditions of operation and use.
- Valves with pneumatic or hydraulic operation:  
The piston rod should be clean and free of dirt. A self-lubricating rod seal is used as standard with pneumatic cylinders with damping. All the seals should be replaced if these cylinders leak.
- Electrically-operated valves:  
The spindle must always be kept well greased and free of dirt. The greasing points on the actuator must be checked. The respective instructions for use of the actuator manufacturer are binding.
- At every routine maintenance the antistatic device at the gate has to be tested regarding damages and has to be replaced if damages were found.

Before starting up after maintenance or repair:

- Check that screw connections are tightly fitted.
- Ensure that all parts removed have been re-assembled.

### **Behavior after failure**

After a break down (e.g. explosion) the valve has to be function-tested by suitably qualified personnel. This is even valid if permitted limits (e.g. explosion pressure) were not reached. It is recommended to let the manufacturer check the valve.

### **Final remarks**

The details given here correspond to the latest state of our knowledge and, in connection with the technical documentation, the purpose of providing information about our products and their range of applications. They are not meant to guarantee particular features of the products or their suitability for specific applications. Any existing copyrights and patent rights must be taken into consideration. We guarantee the quality within the scope of our terms and conditions of sale.

We reserve the right to make changes and improvements.

status: 2007-09-21